

# Specifications

# LEO 23 GT

**TEUPEN**<sup>®</sup>  
...access redefined

## PERFORMANCE

Working height, max.	23,00 m
Horizontal outreach with 200 kg	11,20 m
Up-and-over clearance, max.	11,50 m
Basket capacity	200 kg
Movable jib	-
Basket rotation	180°
Turret rotation	360°
To be jacked up on ground slope of	16,7°/30,0 %
Height and width track adjustment	23/45 cm
Gradeability, max.	16,7°/30,0 %
Slope angle	15,5°/27,0 %
Travel speed	1,3 km/h

## MEASUREMENTS

Platform height (A)	1,10 m
Platform length (B)	1,42 m
Platform width (C)	0,70 m
Length, overall (D)	6,20 m
Length without basket (E)	-
Height, travel position (F)	1,97 m
Width, minimal overall width (G)	0,98 m
Ground clearance, max. (H)	0,40 m
Track (L x W) (I)	1,45 m x 0,20 m
Length outrigger footprint standard (J)	4,53 m
Width outrigger footprint standard (K)	4,33 m
Length footprint one side narrow (L)	5,98 m
Width footprint one side narrow (M)	3,42 m
Width footprint both sides narrow (N)	2,58 m
Outrigger plate Ø	0,18 m

## WEIGHT

Total weight	2990 kg
Live load in travelling position	4,02 kN/m <sup>2</sup>
Live load in working position	1,78 kN/m <sup>2</sup>
Point load per outrigger plate, max.	22,40 kN

## POWER

Standard power sources (electric and combustion engine)	<b>1) Electric:</b> 230 V, 12,9 A, 2,2 kW <b>2) Diesel:</b> Kubota Z 602 (10,8 kW/14,5 hp)
Optional power source	<b>Li-Ion Battery:</b> 48 V
Fuel tank capacity Diesel engine	12,0l

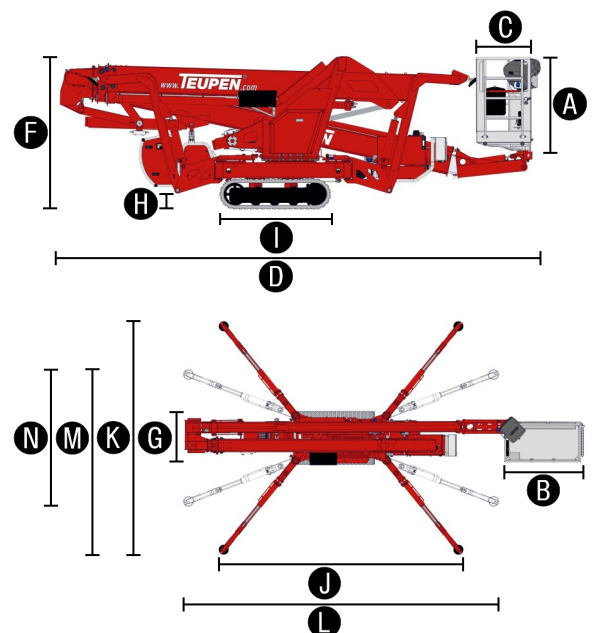
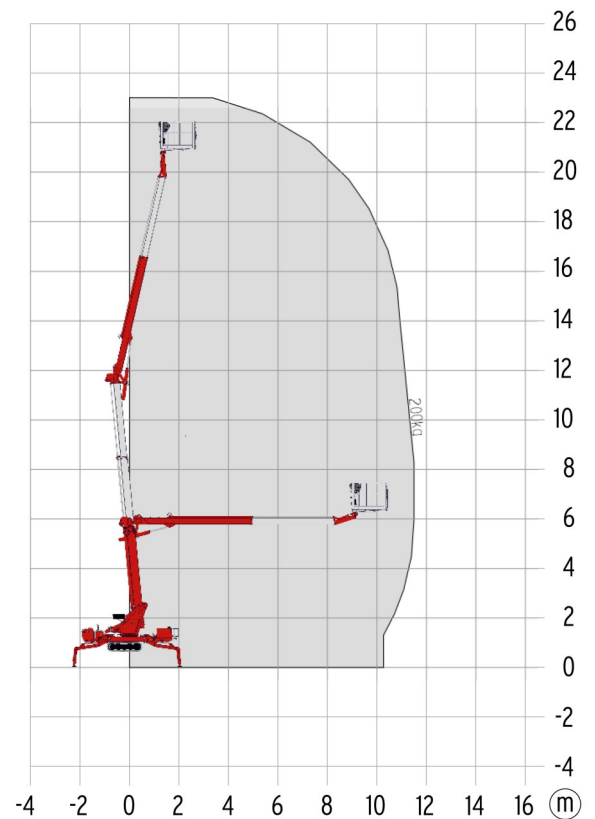

## STANDARDS COMPLIANCE

2006/42/EC-Machinery directive  
(Harmonised standard EN280:2001 + A2:2009); 2004/108/EC (EMC);  
2000/14/EC (Noise emission directive - outdoor)

# Features

# LEO<sup>23</sup>GT

**TEUPEN**<sup>®</sup>  
...access redefined

## CHASSIS

- Powerful track drive with hydraulic braking system
- Precise maneuvering over sensitive electrohydraulic cable remote control
- Indoor non marking rubber track, with less tread depth the profile enables smooth
- Mechanically height- und width-adjustable track chassis

## STABILISATION

- Fully-hydraulic, automatic levelling system with outrigger setup monitoring
- Variable outrigger system with one-side or both-sides narrow setup option
- Wear resistant, anti-friction PVC outrigger feet

## BOOM SYSTEM

- Telescoping upper- and lower booms, trapezium-shaped aluminum profiles
- All functions are available from one control panel
- Electric-proportional controls with intuitive operator guidance
- Robust, lockable control panel with integrated operation function
- Self-levelling platform with electro-hydraulic levelling system
- Corner-mounted, 180° turnable basket for extra flexibility
- Boom rotation via high-performance slew ring, worm gear and hydraulic motor

## POWER

- 230 V electric motor (EU)
- Kubota diesel engine Z602 (10,8 kW/14,5 hp) with electronically regulated engine control
- Start-Stop switch of combustion engine in the basket

## PRODUCTIVITY, SAFETY, QUALITY

- 230 V (EU) power outlet in the basket
- Ergonomically shaped basket with eyelets for safety belts and tool tray
- High-quality paint in RAL 3020 (red)
- Hydraulic emergency lowering via hand pump
- Cables and hoses are safely routed through the boom structure
- Biodegradable hydraulic oil
- Lock valves - hydraulic return valves directly on all hydraulic cylinders
- Relief valves protecting the hydraulic system from too high pressures
- Protective covers for oil-tank, emergency controls and connecting cables and hoses
- Hour meter
- Complete second control box on the chassis and error analysis with display
- Fuzzy IV control technology

## OPTIONS

- Li-Ion battery drive 48 V\* instead of Diesel engine. This option can not be combined with the electric emergency lowering.
- Custom paintwork, one colour, according to RAL scheme (except metallic coatings, signal- or special colors)
- Custom paintwork, two colours, according to RAL scheme (except metallic coatings, signal- or special colors)
- Hydraulically height- und width-adjustable track chassis instead of the mechanically adjustable track chassis
- Electric emergency lowering (12 kg additional weight)  
This option can not be combined with the battery drive
- White, non-marking rubber tracks with specially arranged

*\*When using the Low trailer is this option not possible to keep total weight below the permissible gross laden weight of 3,5t.*

## ACCESSORIES

- Safety harness
- Outrigger pad (450 x 400 x 40 mm)
- Lockable storage frame for outrigger pads (additional weight: approx. 4 kg)
- 4 outrigger/sliding pads (700 x 220 x 60 mm)
- Track mat (2000 x 800 x 15 mm)
- 2 protective track covers, made of high-quality polypropylene fabric
- 4 covers on piston rod (outrigger/stabiliser) cylinders (additional weight: 10 kg)
- 2 LED headlights 10-30 V on engine unit
- Treecare package, consisting of:
  - Protective cover over control box
  - Protective cover telescoping cylinder
  - Covers on piston rod (outrigger/stabiliser) cylinders

## TRAILER

- Tandem Low Platform trailer (aluminium)

## CONTACT

### Teupen Maschinenbau GmbH

Marie-Curie-Str. 13  
48599 Gronau  
Germany

phone +49 (0) 2562 8161-0  
fax +49 (0) 2562 8161-888  
mail@teupen.com

Version 2016-B. Product specifications are subject to change without notice or obligation. Photographs and drawings in this document are for illustrative purposes only. Refer to the appropriate Operator's Manual for instructions on the proper use of this equipment. Failure to follow the appropriate Operator's Manual when using our equipment or to otherwise act irresponsibly may result in serious injury or death. The only warranty applicable to our equipment is the standard written warranty applicable to the particular product and sale and we make no other warranty, expressed or implied. Products and services listed may be trademarks, service marks or trade-names of Teupen Maschinenbau GmbH and/or its subsidiaries in the U.S.A. and many other countries. "Teupen", "Access redefined" and "LEO Series" are registered Trademarks of Teupen GmbH in the United States of America and many other countries. © 2016 Teupen Maschinenbau GmbH.

